

# HSK-T

PRECISION TOOL HOLDERS SYSTEM



HSK-T车铣复合刀座  
CNC TOOL SYSTEMS

## 參考資料

## REFERENCE DETAILS

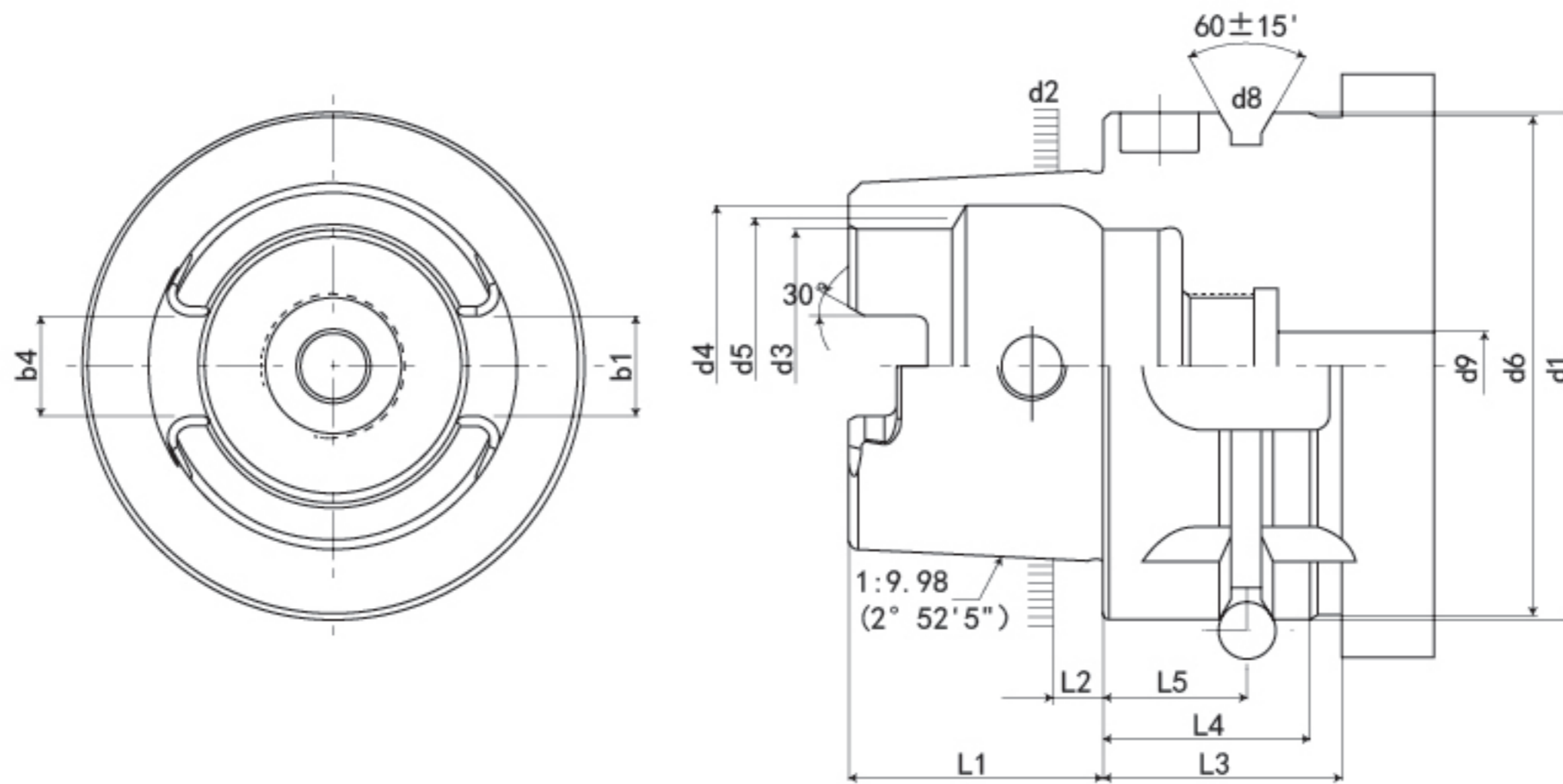

規格 Spec.	$d_1$ h10	$d_2$	$d_3$ H10	$d_4$ H11	$d_5$	$d_6$ Max.	$d_8$	$d_9$ Max.	$L_1$ 0 -0.2	$L_2$	$L_3$ Min.	$L_4$ 0 -0.1	$L_5$ $\pm 0.1$	$b_1$ $\pm 0.04$	$b_4$	
HSK-T32	32	24.007	17	20.5	19	31	4	4.2	16	3.2	23	20	16	7.05	6.932	+0.03 0
HSK-T40	40	30.007	21	25.5	23	39	4	5	20	4	23	20	16	8.05	7.932	+0.03 0
HSK-T50	50	38.009	26	32	29	49	7	6.8	25	5	30	26	18	10.54	10.425	+0.035 0
HSK-T63	63	48.010	34	40	37	62	7	8.4	32	6.3	30	26	18	12.54	12.425	+0.035 0
HSK-T80	80	60.012	42	50	46	79	7	10.2	40	8	30	26	18	16.04	15.93	+0.035 0
HSK-T100	100	75.013	53	63	58	99	7	12	50	10	34	26	20	20.02	19.91	+0.035 0

### 特點:

#### 注:

- 錐度精度 :<AT3
- 硬度 :>HRC56°
- 滲碳深度 :>0.8mm
- 真圓度 :<0.8  $\mu$  m
- 表面粗糙度 :Ra<0.25  $\mu$  m
- 刀杆有預設標準動平衡 G6.3, 可另外指定精密動平衡 G2.5
- 本體規範 :DIN ISO 12164-3:20008

### Features:

- Taper tolerance <AT3.
- Hardness>HRC56°
- Carbon depth>0.8mm.
- Roundness < 0.8um.
- Surface roughness: Ra<0.25um.
- The shank has pre-balance at G6.3,and can provide precision balance at G2.5, made by request.
- Shank body standard:DIN ISO 12164-3:20008



# HSK-T-SBK 外徑車銑復合刀座

## HSK-T-SBK OUTSIDE DIAMETER TURNING AND MILLING TOOL HOLDER

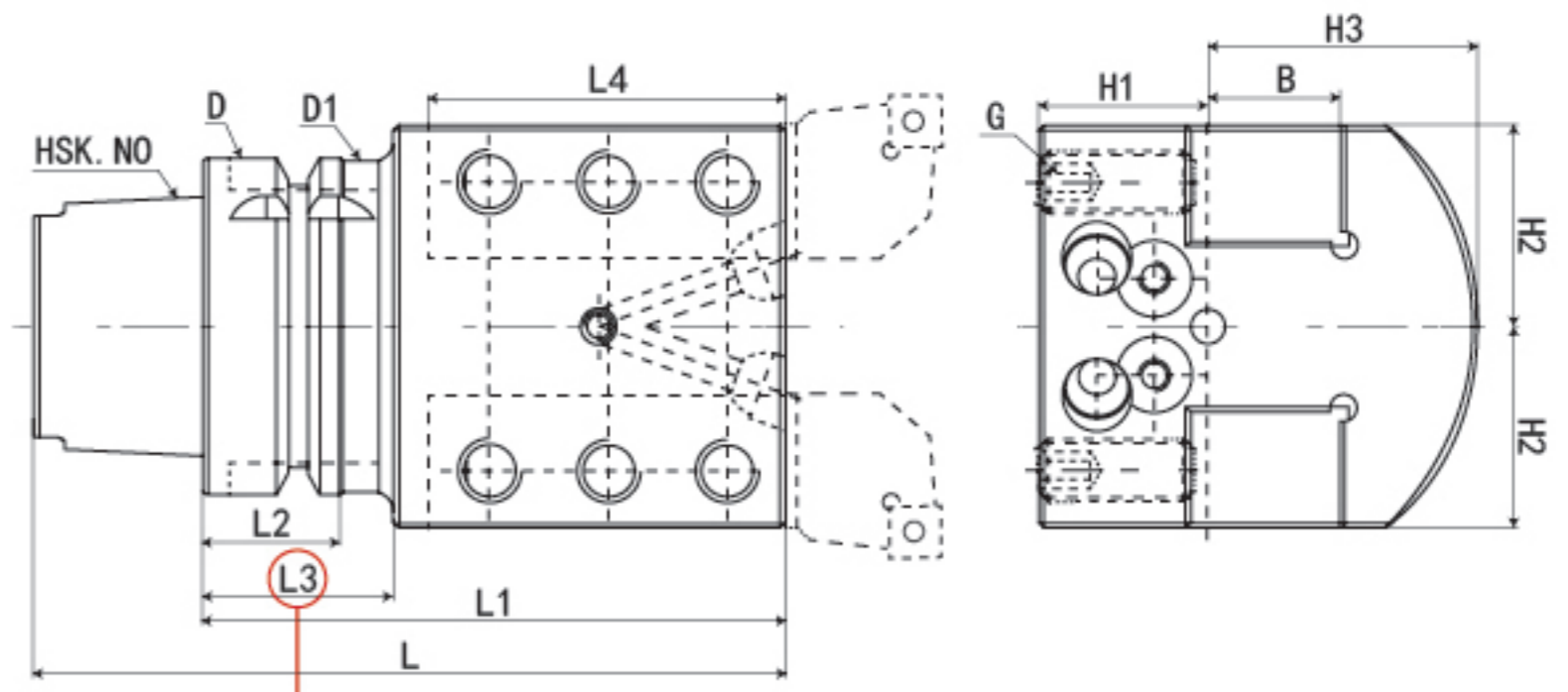
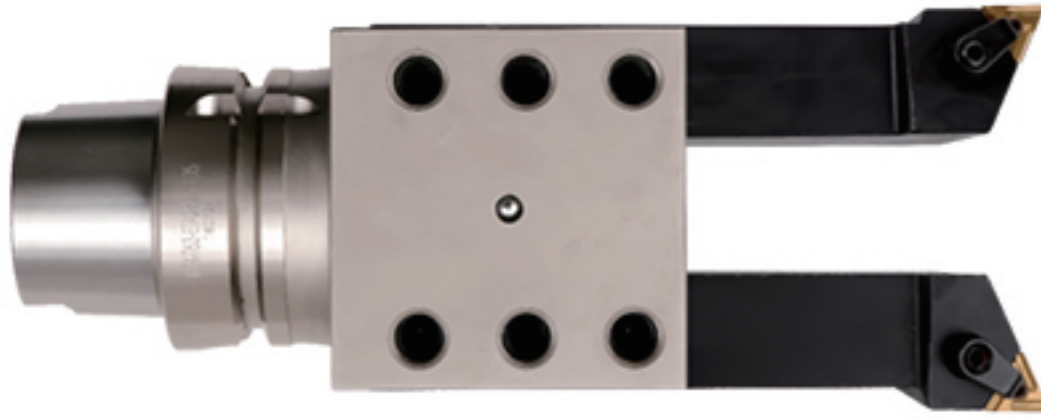

**注意 Note**

★：请注意防止 ATC 悬臂及机械内的干涉  
Please take care to prevent interference within the ATC cantilever and the machine.

不限左右方向  
No restriction on left or right hand direction

规格 Model	柄部	L	L1	L2	L3	L4	D	D1	H1	H2	H3	B	G	重量 KGS
HSK-T50-SBK20*20R-95	HSK-T50	120	95	26	31	60	50	48	32	37.75	51	20	M10*1.5P	2
HSK-T63-SBK20*20R-110	HSK-T63	142	110	26	36	60	63	61	32	37.75	51	20	M10*1.5P	2.5
HSK-T63-SBK25*25R-110	HSK-T63	142	110	26	36	67.5	63	61	32	37.75	51	25	M12*1.75P	2.8
HSK-T63-SBK1" *-1" R-110	HSK-T63	142	110	26	36	67.5	63	61	32	37.75	51	1"	M12*1.75P	2.8
HSK-T100-SBK25*25R-120	HSK-T100	170	120	29	35	110	100	98	32	37.75	51	25	M12*1.75P	6.5
HSK-T100-SBK1" *1" R-120	HSK-T100	170	120	29	35	110	100	98	32	37.75	51	1"	M12*1.75P	6.5

HSK-T Turning and Milling Tool Holder  
HSK-T 車銑復合刀座

## HSK-T-SBN 外徑車銑復合刀座

## HSK-T-SBN OUTSIDE DIAMETER TURNING AND MILLING TOOL HOLDER

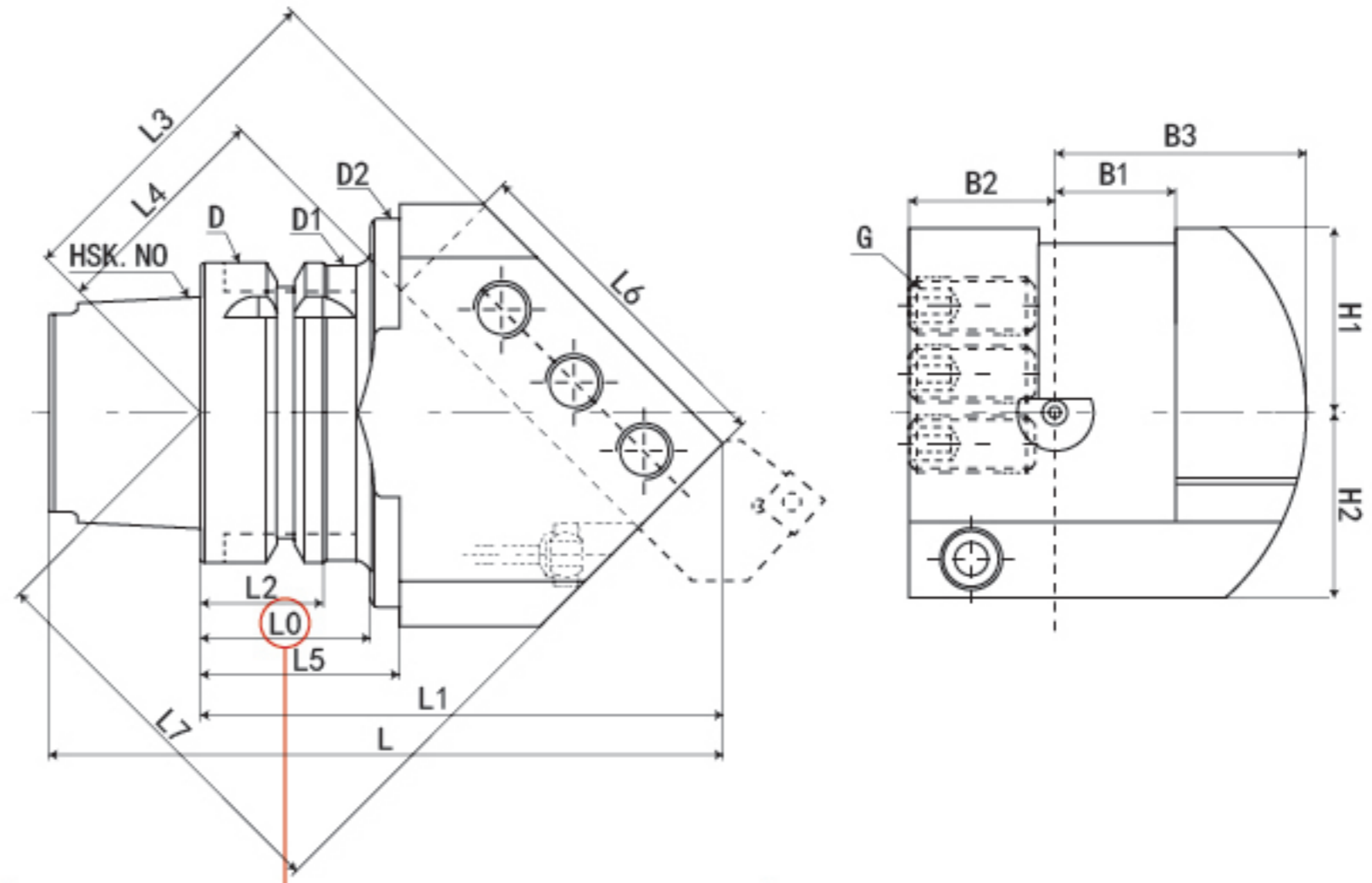

**注意 Note**

★：请注意防止 ATC 悬臂及机械内的干涉  
Please take care to prevent interference within the ATC cantilever and the machine.

本图表示右手车刀 (R)  
This diagram shows a right hand turning tool (R)

規格	柄部	L	L0	L1	L2	L3	L4	L5	L6	L7	D	D1	D2	B1	B2	B3	H1	H2	G	重量 KGS
HSK-T50-SBN20*20R-110	HSK-T50	135	31	110	26	72.8	52.8	*	60	83.1	50	48	*	20	25	43.5	35	35	M10*1.5P	2.4
HSK-T50-SBN20*20L-110	HSK-T50	135	31	110	26	72.8	52.8	*	60	83.1	50	48	*	20	25	43.5	35	35	M10*1.5P	2.4
HSK-T63-SBN20*20R-110	HSK-T63	142	32	110	26	72.8	52.8	*	60	83.1	63	61	*	20	32	43.5	35	35	M10*1.5P	2.9
HSK-T63-SBN20*20L-110	HSK-T63	142	32	110	26	72.8	52.8	*	60	83.1	63	61	*	20	32	43.5	35	35	M10*1.5P	2.9
HSK-T63-SBN25*25R-110	HSK-T63	142	32	110	26	70.8	45.8	40	70	85.2	63	61	90	25	32	53	39	39	M12*1.75P	3.2
HSK-T63-SBN25*25L-110	HSK-T63	142	32	110	26	70.8	45.8	40	70	85.2	63	61	90	25	32	53	39	39	M12*1.75P	3.2
HSK-T63-SBN1" *-1" R-110	HSK-T63	142	32	110	26	70.8	45.8	40	70	85.2	63	61	90	1"	32	53	39	39	M12*1.75P	3.2
HSK-T63-SBN1" *-1" L-110	HSK-T63	142	32	110	26	70.8	45.8	40	70	85.2	63	61	90	1"	32	53	39	39	M12*1.75P	3.2
HSK-T100-SBN25*25R-135	HSK-T100	185	35	135	29	88.5	63.5	*	70	102.9	100	98	*	25	32	59	43	43	M12*1.75P	6.4
HSK-T100-SBN25*25L-135	HSK-T100	185	35	135	29	88.5	63.5	*	70	102.9	100	98	*	25	32	59	43	43	M12*1.75P	6.4
HSK-T100-SBN1" *-1" R-135	HSK-T100	185	35	135	29	88.5	63.5	*	70	102.9	100	98	*	1"	32	59	43	43	M12*1.75P	6.4
HSK-T100-SBN1" *-1" L-135	HSK-T100	185	35	135	29	88.5	63.5	*	70	102.9	100	98	*	1"	32	59	43	43	M12*1.75P	6.4
HSK-T100-SBN32*32R-140	HSK-T100	190	35	140	29	89	59	*	85	109.9	100	98	*	32	37	68.5	48	43	M14*2.0P	7.2
HSK-T100-SBN32*32L-140	HSK-T100	190	35	140	29	89	59	*	85	109.9	100	98	*	32	37	68.5	48	43	M14*2.0P	7.2

HSK-T 車銑復合刀座  
HSK-T Turning and Milling Tool Holder

# HSK-T-SBH 外徑車銑復合刀座

# HSK-T-SBH OUTSIDE DIAMETER TURNING AND MILLING TOOL HOLDER

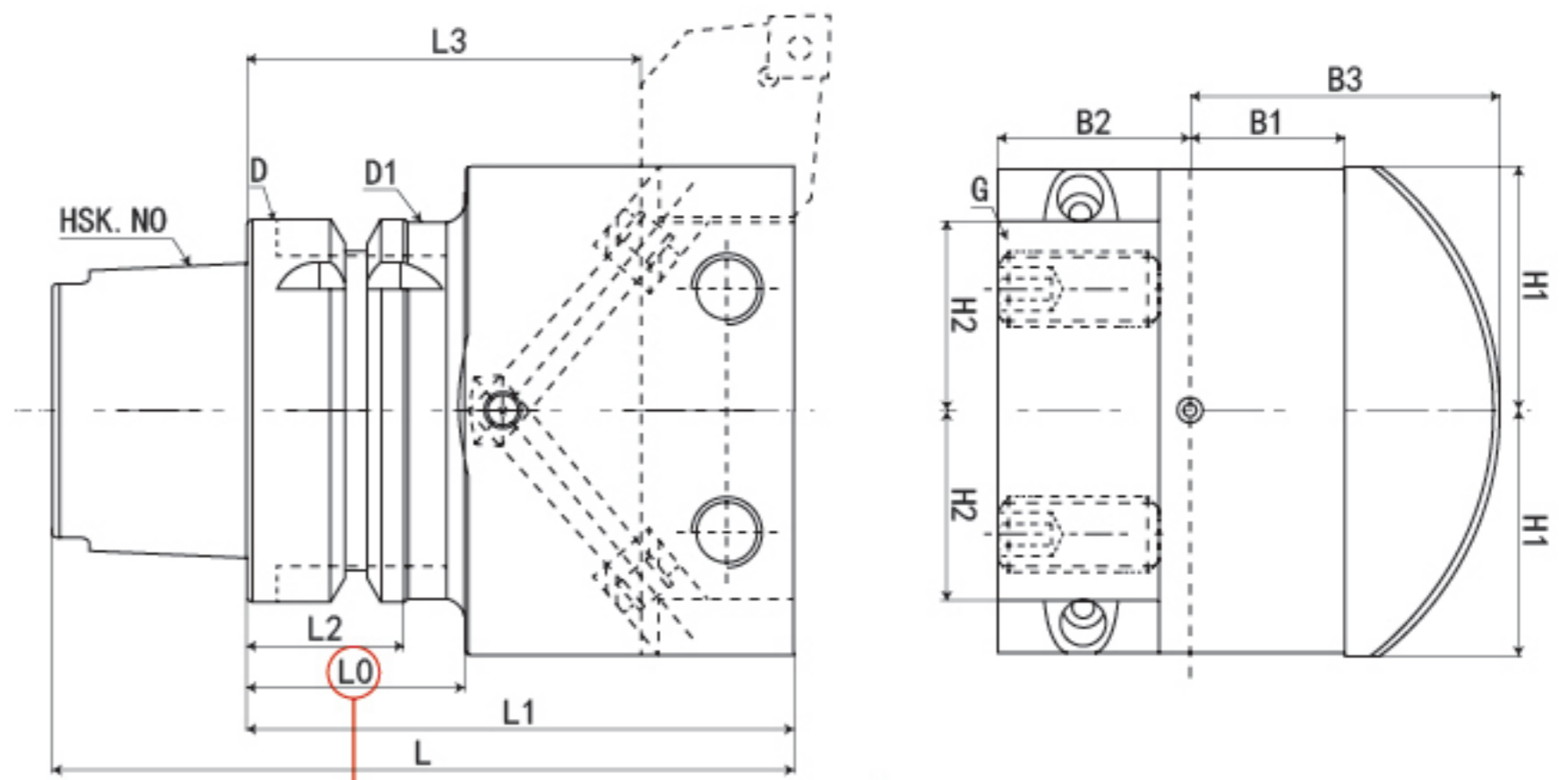

⚠ 注意 Note  
 ★：请注意防止 ATC 悬臂及机械内的干涉  
 Please take care to prevent interference within the ATC cantilever and the machine.

不限左右方向  
 No restriction on left or right hand direction

规格	柄部	L	L0	L1	L2	L3	D	D1	B1	B2	B3	H1	H2	G	重量 KGS
HSK-T50-SBH20*20R-90	HSK-T50	115	40	90	26	70	50	48	20	25	43.5	27.5	*	M10*1.5P	1.8
HSK-T50-SBH20*20R-120	HSK-T50	145	70	120	26	100	50	48	20	25	43.5	27.5	*	M10*1.5P	2.3
HSK-T63-SBH20*20R-90	HSK-T63	122	40	90	26	70	63	61	20	32	4.35	30	*	M10*1.5P	2.5
HSK-T63-SBH25*25R-90	HSK-T63	122	40	90	26	65	63	61	25	32	53	40.5	29.5	M12*1.75P	3.1
HSK-T63-SBH1" *-1" R-90	HSK-T63	122	40	90	26	65	63	61	1"	32	53	40.5	29.5	M12*1.75P	3.1
HSK-T63-SBH25*25R-120	HSK-T63	152	70	120	26	95	63	61	25	32	53	40.5	29.5	M12*1.75P	3.7
HSK-T63-SBH1" *-1" R-120	HSK-T63	152	70	120	26	95	63	61	1"	32	53	40.5	29.5	M12*1.75P	3.7
HSK-T100-SBH25*25R-105	HSK-T100	155	35	105	29	80	100	98	25	32	59	48	37	M12*1.75P	6.1
HSK-T100-SBH1" *-1" R-105	HSK-T100	155	35	105	29	80	100	98	1"	32	59	48	37	M12*1.75P	6.1
HSK-T100-SBH25*25R-150	HSK-T100	200	35	150	29	125	100	98	25	32	59	48	37	M12*1.75P	8.9
HSK-T100-SBH32*32R-105	HSK-T100	155	35	105	29	75	100	98	32	40	68.5	57	43	M14*2.0P	7.4



## HSK-T-SBV 外徑車銑復合刀座

## HSK-T-SBV OUTSIDE DIAMETER TURNING AND MILLING TOOL HOLDER

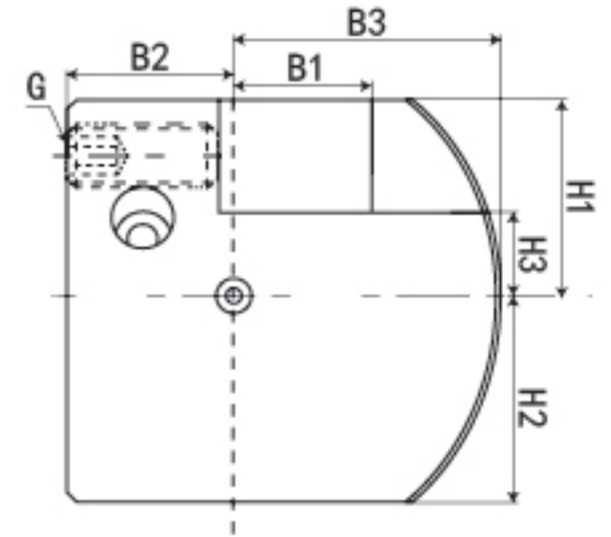
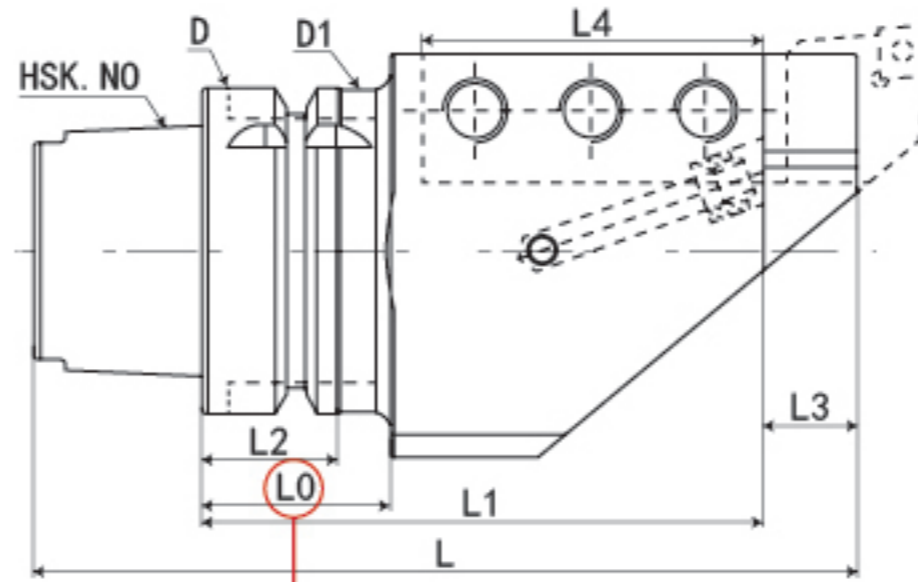

**注意 Note**

★：请注意防止 ATC 悬臂及机械内的干涉  
Please take care to prevent interference within the ATC cantilever and the machine.

本图表示右手车刀 (R)  
This diagram shows a right hand turning tool (R)

规格	柄部	L	L0	L1	L2	L3	L4	D	D1	B1	B2	B3	H1	H2	H3	G	重量 GS
HSK-T50-SBV20*20R-95	HSK-T50	120	31	95	26	15	60	50	48	20	25	43.5	25	25	5	M10*1.5P	2
HSK-T50-SBV20*20L-95	HSK-T50	120	31	95	26	15	60	50	48	20	25	43.5	25	25	5	M10*1.5P	2
HSK-T63-SBV20*20R-95	HSK-T63	127	32	95	26	15	60	63	61	20	32	43.5	33	32	13	M10*1.5P	2.7
HSK-T63-SBV20*20L-95	HSK-T63	127	32	95	26	15	60	63	61	20	32	43.5	33	32	13	M10*1.5P	2.7
HSK-T63-SBV25*25R-105	HSK-T63	137	32	105	26	20	70	63	61	25	32	45	30	30	5	M12*1.75P	2.9
HSK-T63-SBV25*25L-105	HSK-T63	137	32	105	26	20	70	63	61	25	32	45	30	30	5	M12*1.75P	2.9
HSK-T63-SBV1" *-1" R-105	HSK-T63	137	32	105	26	20	70	63	61	25	32	45	30	30	5	M12*1.75P	2.9
HSK-T63-SBV1" *-1" L-105	HSK-T63	137	32	105	26	20	70	63	61	25	32	45	30	30	5	M12*1.75P	2.9
HSK-T100-SBV25*25R-150	HSK-T100	200	35	150	29	20	110	100	98	25	37	59	48	43	23	M12*1.75P	8.5
HSK-T100-SBV25*25L-150	HSK-T100	200	35	150	29	20	110	100	98	25	37	59	48	43	23	M12*1.75P	8.5
HSK-T100-SBV1" *-1" R-150	HSK-T100	200	35	150	29	20	110	100	98	1"	37	59	48	43	23	M12*1.75P	8.5
HSK-T100-SBV1" *-1" L-150	HSK-T100	200	35	150	29	20	110	100	98	1"	37	59	48	43	23	M12*1.75P	8.5
HSK-T100-SBV32*32R-150	HSK-T100	200	35	150	29	20	110	100	98	32	40	68.5	45	43	15	M14*2.0P	9
HSK-T100-SBV32*32L-150	HSK-T100	200	35	150	29	20	110	100	98	32	40	68.5	45	43	15	M14*2.0P	9

HSK-T 車銑復合刀座  
HSK-T Turning and Milling Tool Holder

# HSK-T-SBT 外徑車銑復合刀座

# HSK-T-SBT OUTSIDE DIAMETER TURNING AND MILLING TOOL HOLDER

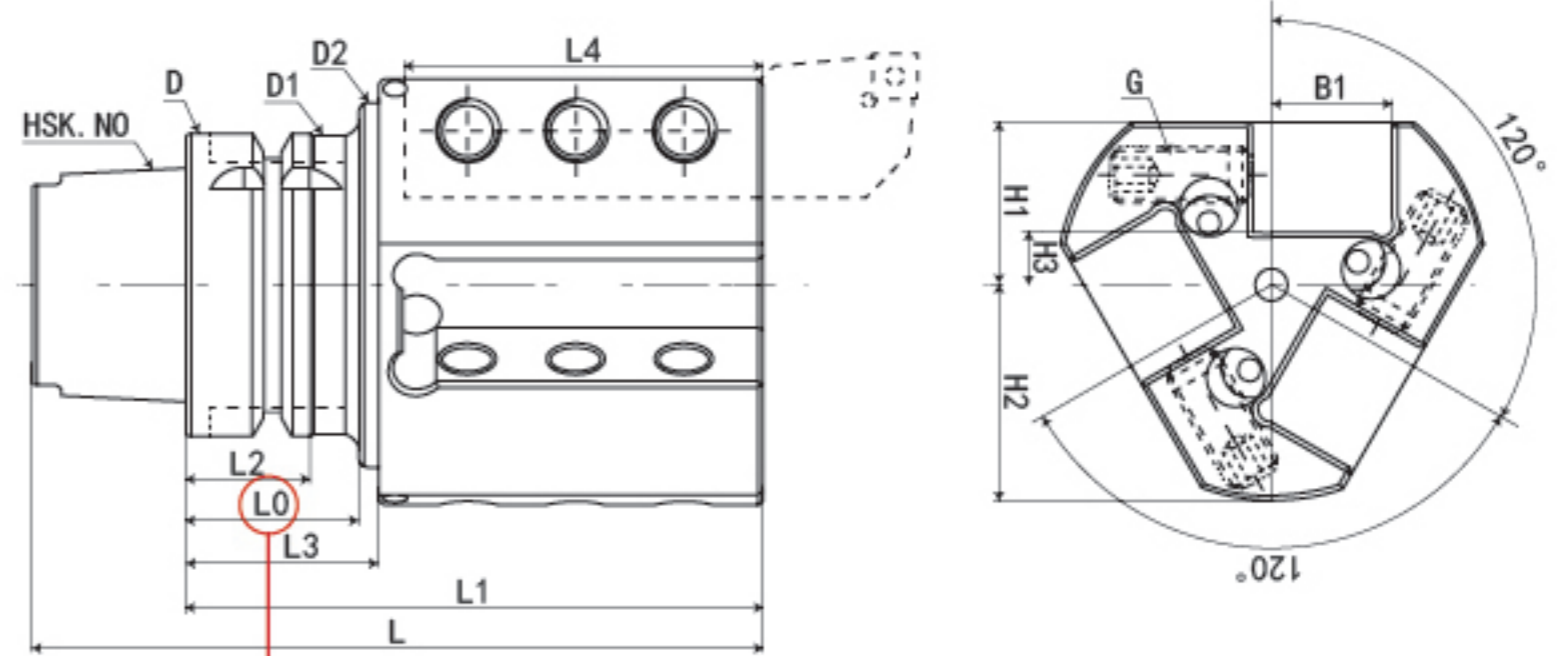

⚠注意 Note  
 ★：请注意防止 ATC 悬臂及机械内的干涉  
 Please take care to prevent interference within the ATC cantilever and the machine.

本图表示右手车刀 (R)  
 This diagram shows a right hand turning tool (R)



规格	柄部	L	L0	L1	L2	L3	L4	D	D1	D2	B1	H1	H2	H3	G	重量 KGS
HSK-T50-SBT20*20R-95	HSK-T50	120	31	95	26	*	60	50	48	*	20	35	43.5	15	M10*1.5P	2.3
HSK-T50-SBT20*20L-95	HSK-T50	120	31	95	26	*	60	50	48	*	20	35	43.5	15	M10*1.5P	2.3
HSK-T63-SBT20*20R-95	HSK-T63	127	32	95	26	*	60	63	61	*	20	35	43.5	15	M10*1.5P	2.6
HSK-T63-SBT20*20L-95	HSK-T63	127	32	95	26	*	60	63	61	*	20	35	43.5	15	M10*1.5P	2.6
HSK-T63-SBT25*25R-115	HSK-T63	147	32	115	26	40	70	63	61	90	25	43	53	18	M12*1.75P	4.4
HSK-T63-SBT25*25L-115	HSK-T63	147	32	115	26	40	70	63	61	90	25	43	53	18	M12*1.75P	4.4
HSK-T63-SBT1" *-1" R-115	HSK-T63	147	32	115	26	40	70	63	61	90	25	43	53	18	M12*1.75P	4.4
HSK-T63-SBT1" *-1" L-115	HSK-T63	147	32	115	26	40	70	63	61	90	25	43	53	18	M12*1.75P	4.4
HSK-T100-SBT25*25R-150	HSK-T100	200	35	150	29	*	110	100	98	*	25	48	59	23	M12*1.75P	8.9
HSK-T100-SBT25*25L-150	HSK-T100	200	35	150	29	*	110	100	98	*	25	48	59	23	M12*1.75P	8.9
HSK-T100-SBT1" *-1" R-150	HSK-T100	200	35	150	29	*	110	100	98	*	25	48	59	23	M12*1.75P	8.9
HSK-T100-SBT1" *-1" L-150	HSK-T100	200	35	150	29	*	110	100	98	*	25	48	59	23	M12*1.75P	8.9

## HSK-T-TSB 內徑車銑複合刀座 [ 鏜刀杆用 ]

HSK-T-TSB INNER DIAMETER TURNING AND MILLING TOOL HOLDER (FOR BORING BAR)

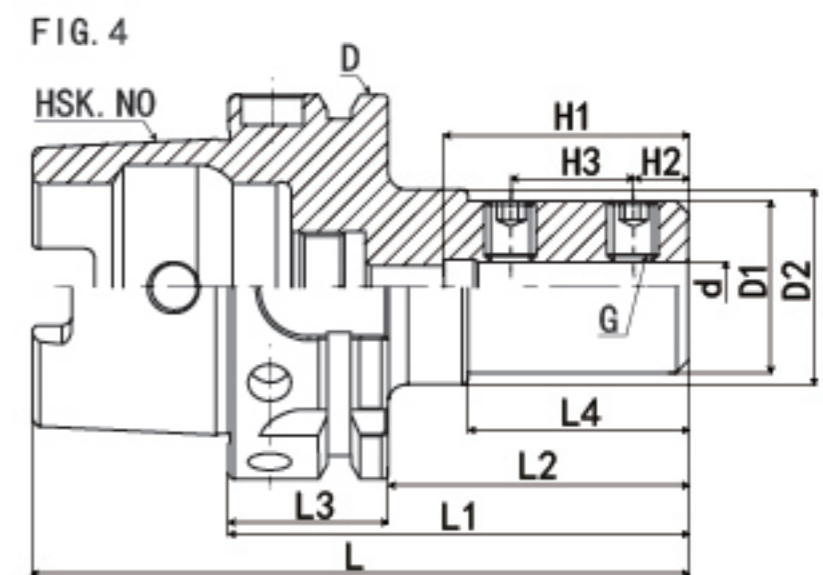
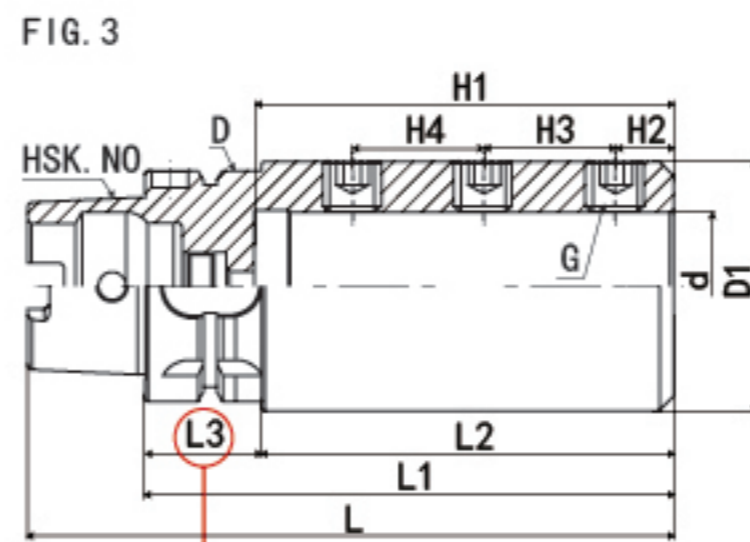
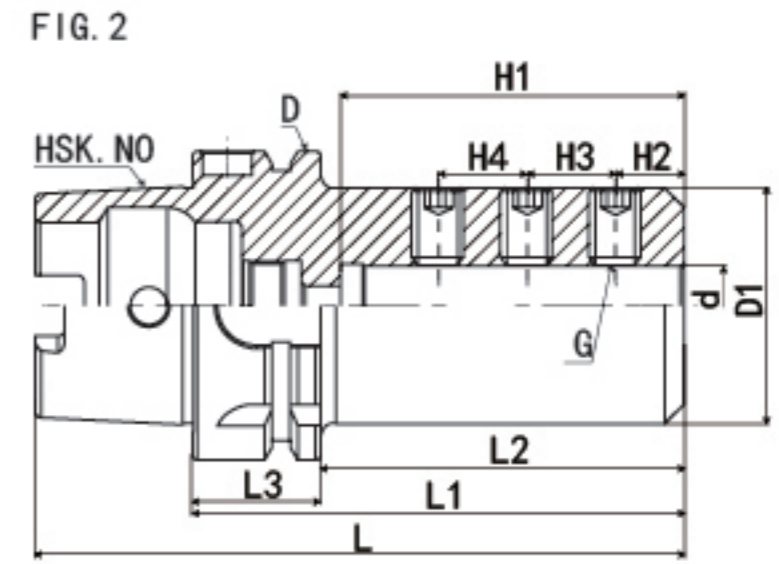
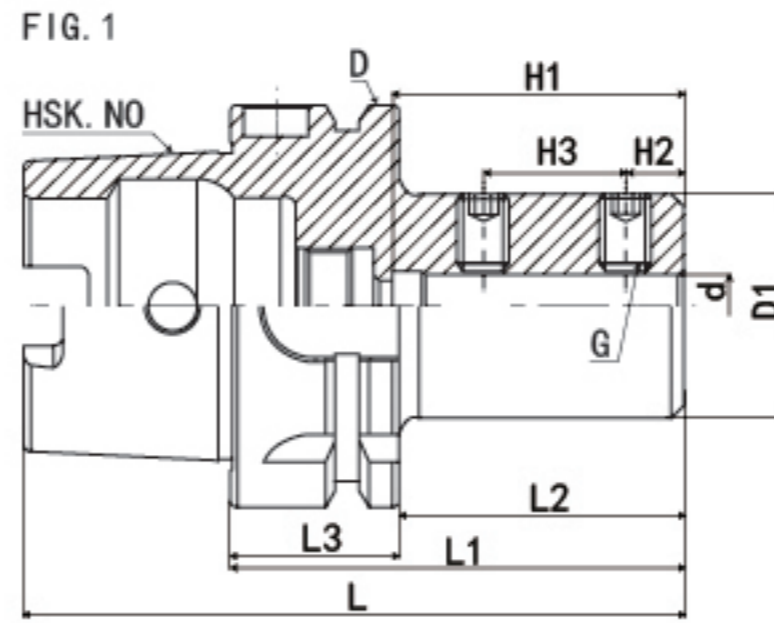

注意 Note  
 ★：请注意防止 ATC 悬臂及机械内的干涉  
 Please take care to prevent interference within the ATC cantilever and the machine.

規格	柄部	L	L1	L2	L3	L4	D	D1	D2	d	H1	H2	H3	H4	G	FIG	重量 KGS
HSK-T50-TSB8-65	HSK-T50	90	65	39	26	*	50	28	*	8	40	9	20	*	M8*1.25P	1	0.7
HSK-T50-TSB10-70	HSK-T50	95	70	44	26	*	50	35	*	10	45	9	22	*	M8*1.25P	1	0.8
HSK-T50-TSB12-75	HSK-T50	100	75	49	26	*	50	42	*	12	50	9	22	*	M8*1.25P	1	1
HSK-T50-TSB16-95	HSK-T50	120	95	69	26	*	50	48	*	16	70	14	18	18	M10*1.5P	2	1.3
HSK-T50-TSB20-95	HSK-T50	120	95	69	26	*	50	52	*	20	70	14	18	18	M10*1.5P	3	1.4
HSK-T50-TSB25-110	HSK-T50	135	110	84	26	*	50	62	*	25	85	14	26	26	M12*1.75P	3	2.1
HSK-T50-TSB32-125	HSK-T50	150	125	99	26	*	50	62	*	32	100	14	30	30	M12*1.75P	3	2.1
HSK-T63-TSB8-65	HSK-T63	97	65	39	26	*	63	28	*	8	40	9	20	*	M8*1.25P	1	0.9
HSK-T63-TSB10-70	HSK-T63	102	70	44	26	*	63	35	*	10	45	9	22	*	M8*1.25P	1	1.1
HSK-T63-TSB12-75	HSK-T63	107	75	49	26	*	63	42	*	12	50	9	22	*	M8*1.25P	1	1.2
HSK-T63-TSB16-100	HSK-T63	132	100	74	26	*	63	48	*	16	70	14	18	18	M10*1.5P	2	1.7
HSK-T63-TSB20-100	HSK-T63	132	100	74	26	*	63	52	*	20	70	14	18	18	M10*1.5P	2	1.8
HSK-T63-TSB25-115	HSK-T63	147	115	89	26	*	63	62	*	25	85	14	26	26	M12*1.75P	2	2.5
HSK-T63-TSB32-130	HSK-T63	162	130	104	26	*	63	62	*	32	100	14	30	30	M12*1.75P	2	2.6
HSK-T63-TSB40-145	HSK-T63	177	145	119	26	*	63	68	*	40	115	16	36	36	M16*2.0P	3	2.9
HSK-T100-TSB8-75	HSK-T100	125	75	46	29	36	100	28	32	8	40	9	20	*	M8*1.25P	4	2.4
HSK-T100-TSB10-80	HSK-T100	130	80	51	29	*	100	35	*	10	45	9	22	*	M8*1.25P	1	2.5
HSK-T100-TSB12-85	HSK-T100	135	85	56	29	*	100	42	*	12	50	9	22	*	M8*1.25P	1	2.7
HSK-T100-TSB16-105	HSK-T100	155	105	76	29	*	100	48	*	16	70	14	18	18	M10*1.5P	2	3.1
HSK-T100-TSB20-105	HSK-T100	155	105	76	29	*	100	52	*	20	70	14	18	18	M10*1.5P	2	3.2
HSK-T100-TSB25-120	HSK-T100	170	120	91	29	*	100	62	*	25	85	14	26	26	M12*1.75P	2	4
HSK-T100-TSB32-135	HSK-T100	185	135	106	29	*	100	72	*	32	100	14	30	30	M12*1.75P	2	4.9
HSK-T100-TSB40-150	HSK-T100	200	150	121	29	*	100	82	*	40	115	16	36	36	M16*2.0P	2	6
HSK-T100-TSB50-180	HSK-T100	230	180	151	29	*	100	92	*	50	145	18	38	38	M16*2.0P	2	7.8



# TSB40 轉換套

## TSB40 CONVERSION SLEEVE

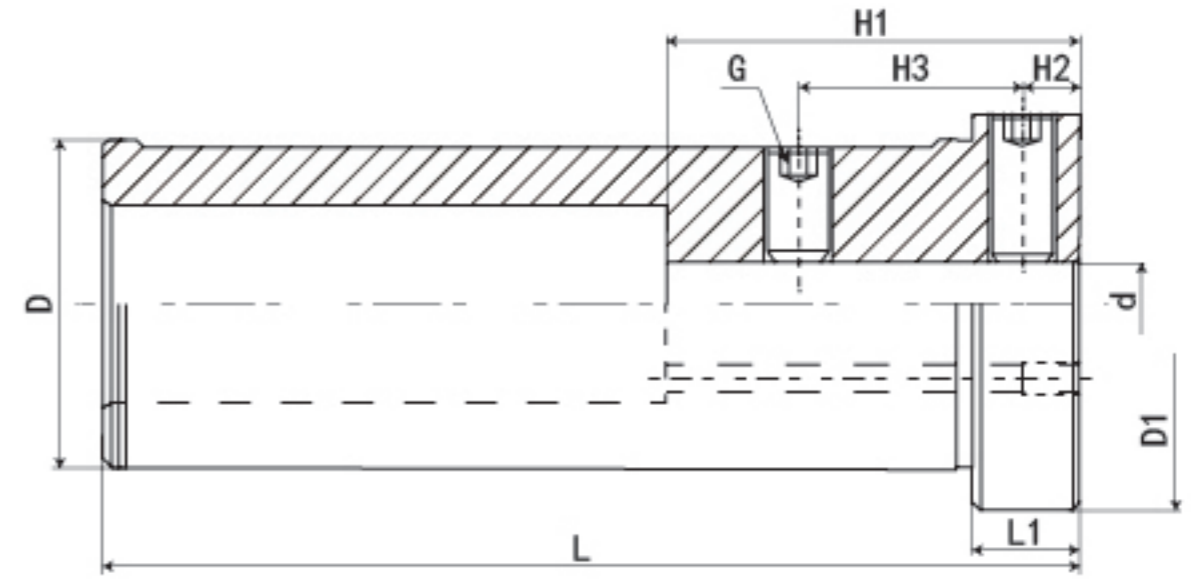
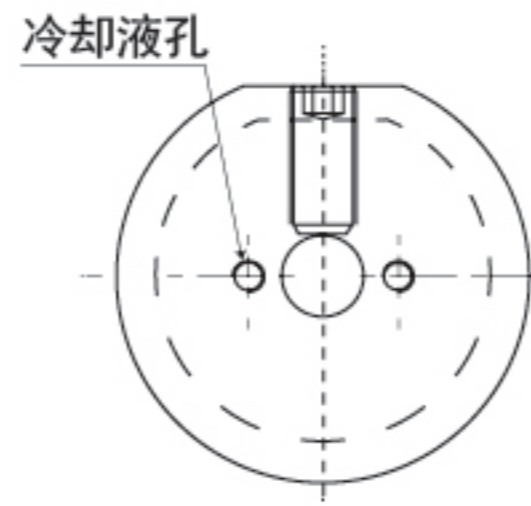

規格	L	L1	D	D1	d	H1	H2	H3	G	重量 KGS
TSB40-8	118	13	40	50	8	50	7	34	M8*1.25P	1
TSB40-10	118	13	40	50	10	50	7	34	M8*1.25P	1
TSB40-12	118	13	40	50	12	60	7	34	M8*1.25P	1
TSB40-16	118	13	40	50	16	70	7	34	M8*1.25P	0.9

HSK-Turning and Milling Tool Holder

## HSK-T-TSD 內徑車銑複合刀座【鑽頭用】

HSKT-TSD INNE-R DIAMETER TURNING AND MILLING TOOL HOLDER (FOR DRILL)

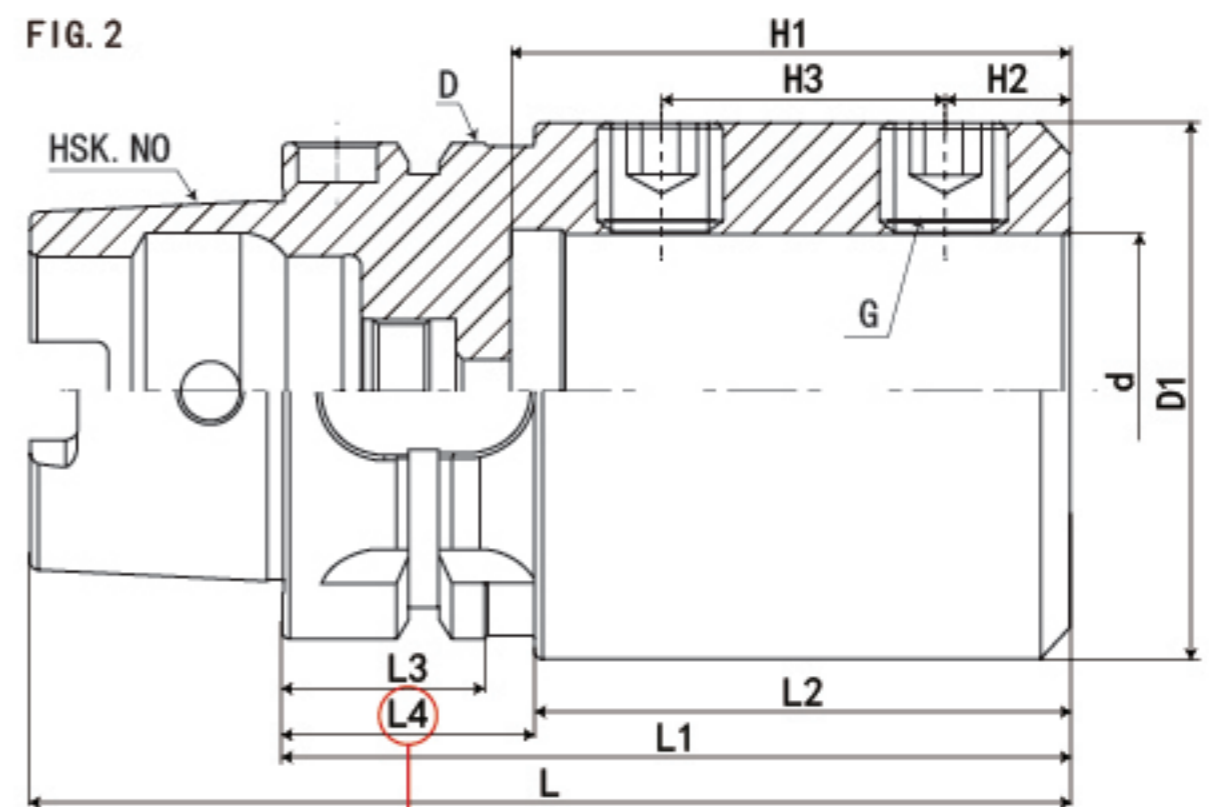
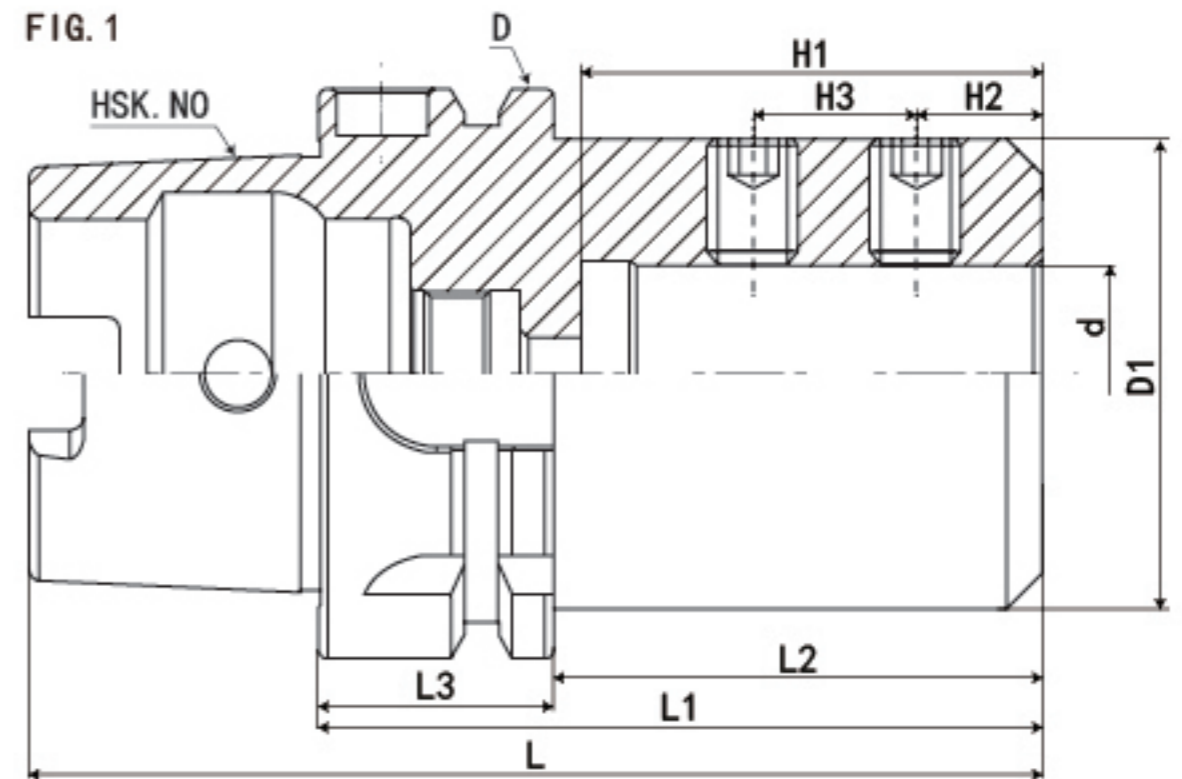

⚠ 注意 Note  
 ★：请注意防止 ATC 悬臂及机械内的干涉  
 Please take care to prevent interference within the ATC cantilever and the machine.

規格	柄部	L	L1	L2	L3	L4	D	D1	d	H1	H2	H3	G	FIG	重量 KGS
HSK-T50-TSD8-65	HSK-T50	90	65	39	26	*	50	28	8	34	10	18	M8*1.25P	1	0.8
HSK-T50-TSD10-65	HSK-T50	90	65	39	26	*	50	35	10	39	12	20	M8*1.25P	1	0.9
HSK-T50-TSD12-70	HSK-T50	95	70	44	26	*	50	42	12	39	12	20	M8*1.25P	1	1
HSK-T50-TSD16-75	HSK-T50	100	75	49	26	*	50	48	16	49	14	18	M10*1.5P	1	1.1
HSK-T50-TSD20-80	HSK-T50	105	80	54	26	31	50	52	20	51	14	18	M10*1.5P	2	1.2
HSK-T50-TSD25-85	HSK-T50	110	85	59	26	31	50	62	25	57	14	26	M12*1.75P	2	1.6
HSK-T50-TSD32-90	HSK-T50	115	90	64	26	31	50	62	32	61	14	30	M12*1.75P	2	1.6
HSK-T63-TSD8-65	HSK-T63	97	65	39	26	*	63	28	8	34	10	18	M8*1.25P	1	0.84
HSK-T63-TSD10-70	HSK-T63	102	70	44	26	*	63	35	10	39	12	20	M8*1.25P	1	0.97
HSK-T63-TSD12-70	HSK-T63	102	70	44	26	*	63	42	12	39	12	20	M8*1.25P	1	1.1
HSK-T63-TSD16-75	HSK-T63	107	75	49	26	*	63	48	16	49	14	18	M10*1.5P	1	1.4
HSK-T63-TSD20-80	HSK-T63	112	80	54	26	*	63	52	20	51	14	18	M10*1.5P	1	1.5
HSK-T63-TSD25-85	HSK-T63	117	85	59	26	*	63	62	25	57	14	26	M12*1.75P	1	1.9
HSK-T63-TSD32-90	HSK-T63	122	90	64	26	*	63	62	32	61	14	30	M12*1.75P	1	1.9
HSK-T63-TSD40-100	HSK-T63	132	100	74	26	32	63	68	40	71	16	36	M16*2.0P	2	2.1
HSK-T100-TSD8-70	HSK-T100	120	70	41	29	*	100	28	8	34	10	18	M8*1.25P	1	2.5
HSK-T100-TSD10-75	HSK-T100	125	75	46	29	*	100	35	10	39	12	20	M8*1.25P	1	2.6
HSK-T100-TSD12-75	HSK-T100	125	75	46	29	*	100	42	12	39	12	20	M8*1.25P	1	2.7
HSK-T100-TSD16-85	HSK-T100	135	85	56	29	*	100	48	16	49	14	18	M10*1.5P	1	2.9
HSK-T100-TSD20-85	HSK-T100	135	85	56	29	*	100	52	20	51	14	18	M10*1.5P	1	2.9
HSK-T100-TSD25-90	HSK-T100	140	90	61	29	*	100	62	25	57	14	26	M12*1.75P	1	3.3
HSK-T100-TSD32-95	HSK-T100	145	95	66	29	*	100	72	32	61	14	30	M12*1.75P	1	3.9
HSK-T100-TSD40-105	HSK-T100	155	105	76	29	*	100	82	40	71	16	36	M16*2.0P	1	4.6
HSK-T100-TSD50-115	HSK-T100	165	115	86	29	*	100	92	50	81	18	38	M16*2.0P	1	5.3

# 車刀規格介紹

## DISPLAY FOR TURNING TOOLS

鎖固方式 CLAMP MECHANISM			
A	BACK CLAMP SYSTEM	M	MULTI-CLAMP SYSTEM
C	CLAMP-ON SYSTEM	P	PIN LOCK SYSTEM
D	DOUBLE CLAMP SYSTEM	S	SCREW-ON SYSTEM
E	OFF-SET PIN SYSTEM	T	TAPER LOCK SYSTEM
JS	SCREW-ON SYSTEM	W	WEDGE-ON SYSTEM
JT	BACK CLAMP SYSTEM		

離隙角 INSERT CLEARANCE	
A	3°
B	5°
C	7°
D	15°
E	20°
F	25°
G	30°
N	0°
P	11°

刀具長度 INSERT EDGE LENGTH					
Insert inscribed circle	6.35	7.94	9.525	12.00	12.70
80°	06	08	09	-	12
55°	07	-	11	-	15
35°	11	-	16	-	-
	-	-	-	12	-
	11	13	16	-	22
	-	-	09	-	12

**HSK-T63** -- **M** **C** **L** **N** **R** **45** **065** - **12**

刀片形狀 INSERT GEOMETRY	
C	80°
D	55°
K	55°
R	
S	
T	
V	35°
W	80°
L	
H	120°
A	85°
B	82°
E	75°
M	86°
O	135°
P	108°

進刀角度 CUTTING EDGE GEMOETRY			
90°	75°	90°	45°
60°	90°	90°	107.5°
93°	75°	95°	50°
63°	117.5°	75°	45°
60°	93°	72.5°	60°
85°			

切削方向 HAND
R
L
N

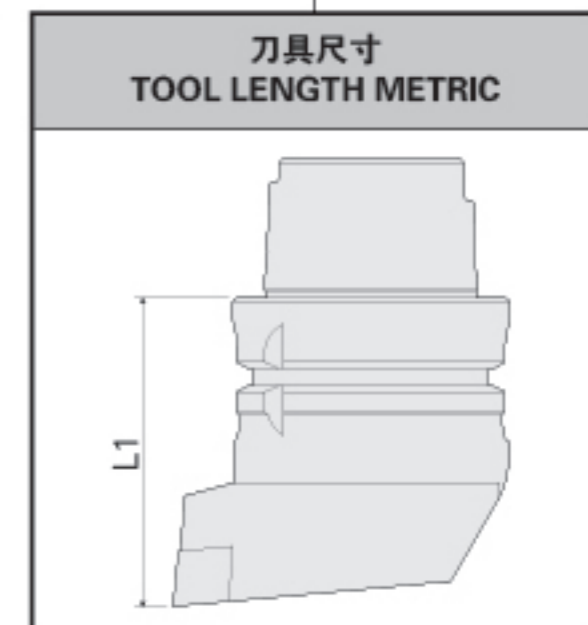
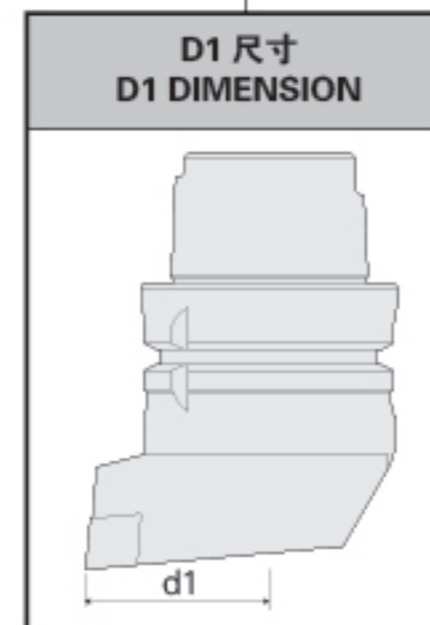

HSK-T Turning and Milling Tool Holder  
HSK-T 車銑複合力座

## DCLN 外徑車刀

## DCLN EXTERNAL TURNING TOOL

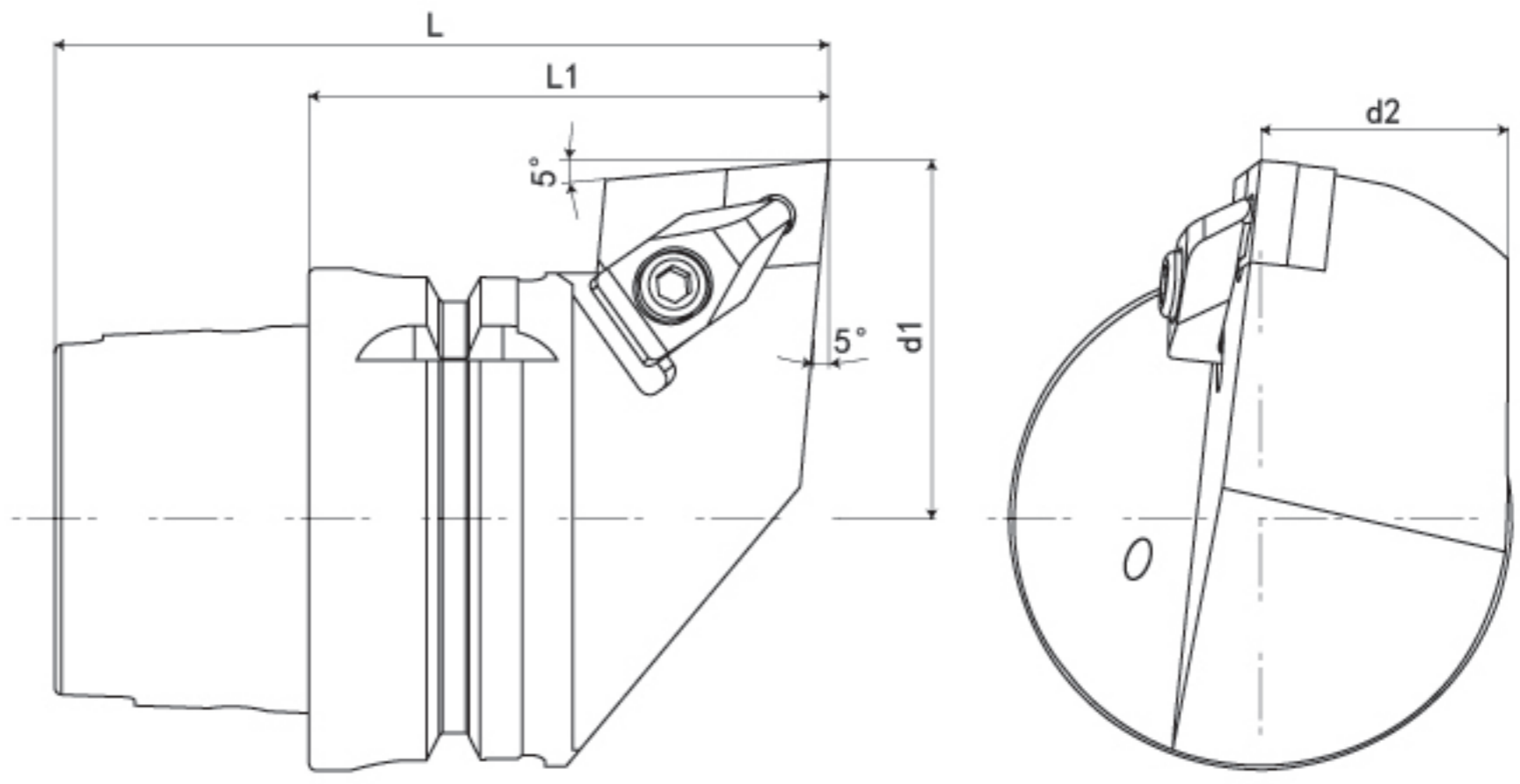

規格 Spec.	L	L1	d1	d2	刀片 Insert	重量 (KGS) Weight
HSK-T63-DCLNR-45065-12	97	65	45	31	CN..1204	1.26
HSK-T63-DCLNL-45065-12	97	65	45	31	CN..1204	1.26

### 配件表 Accessories

刀片 Insert	墊片 Shim	墊片螺絲 Shim Screw	扳手 Wrench	扭力值 (N.m) Torque	壓板 Clamp	壓板螺絲 Clamp Screw	壓板扳手 Clamp Wrench	扭力值 (N.m) Torque
CN..1204	CMS432	MLP46L-A	PL2.5	5.0	MC620	MS630	PL3	5.0

## DDJN 外徑車刀

## DDJN EXTERNAL TURNING TOOL

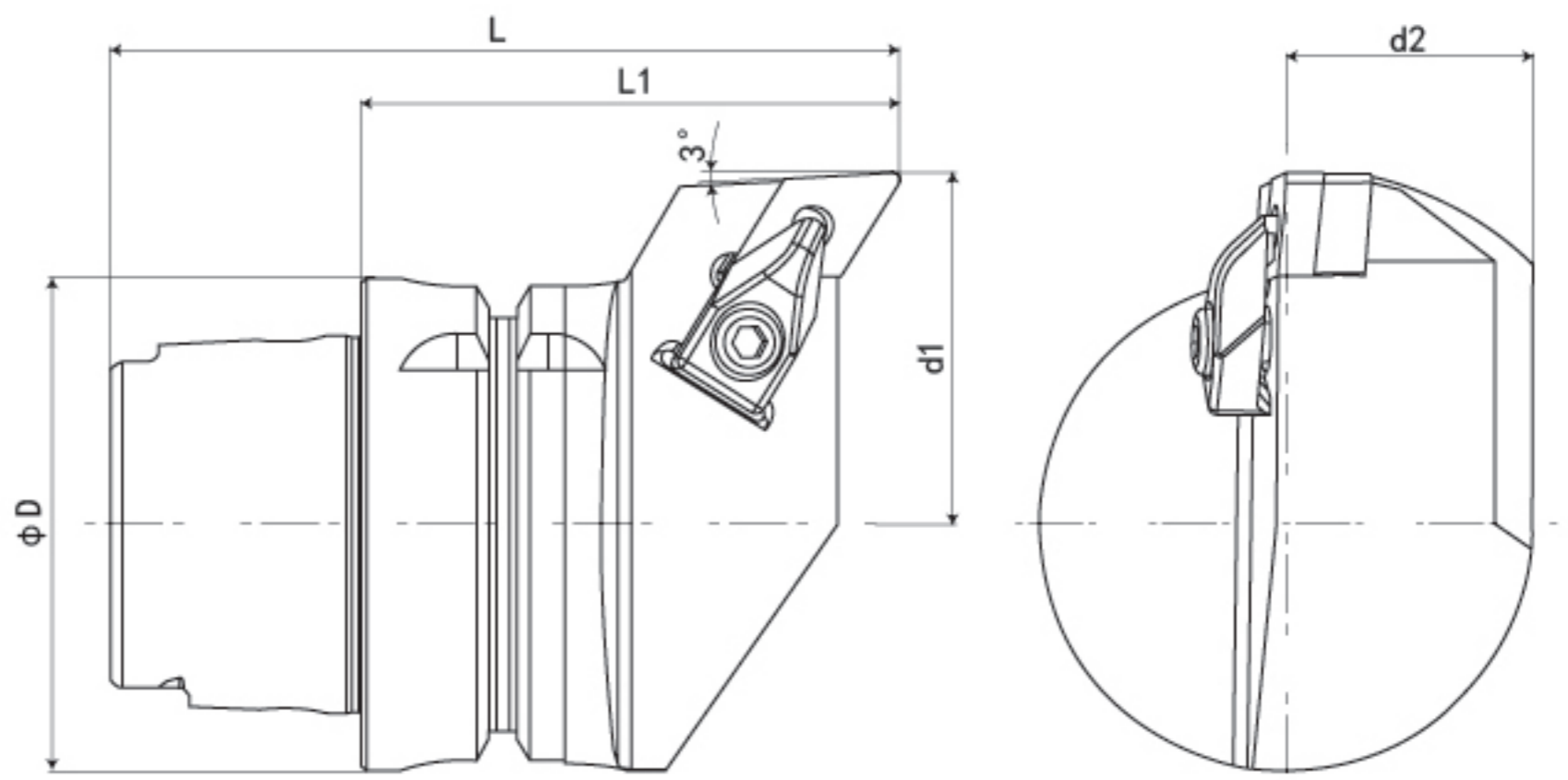

規格 Spec.	L	L1	d1	d2	刀片 Insert	重量 (KGS) Weight
HSK-T63-DDJNR-45075-15	107	75	45	31	DN..1504	1.38
HSK-T63-DDJNL-45075-15	107	75	45	31	DN..1504	1.38

### 配件表 Accessories

刀片 Insert	墊片 Shim	墊片螺絲 Shim Screw	扳手 Wrench	扭力值 (N.m) Torque	壓板 Clamp	壓板螺絲 Clamp Screw	壓板扳手 Clamp Wrench	扭力值 (N.m) Torque
DN..1504	DMS442	MLP46L-A	PL2.5	5.0	MC622	MS630	PL3	5.0

## DTJN 外徑車刀

## DTJN EXTERNAL TURNING TOOL

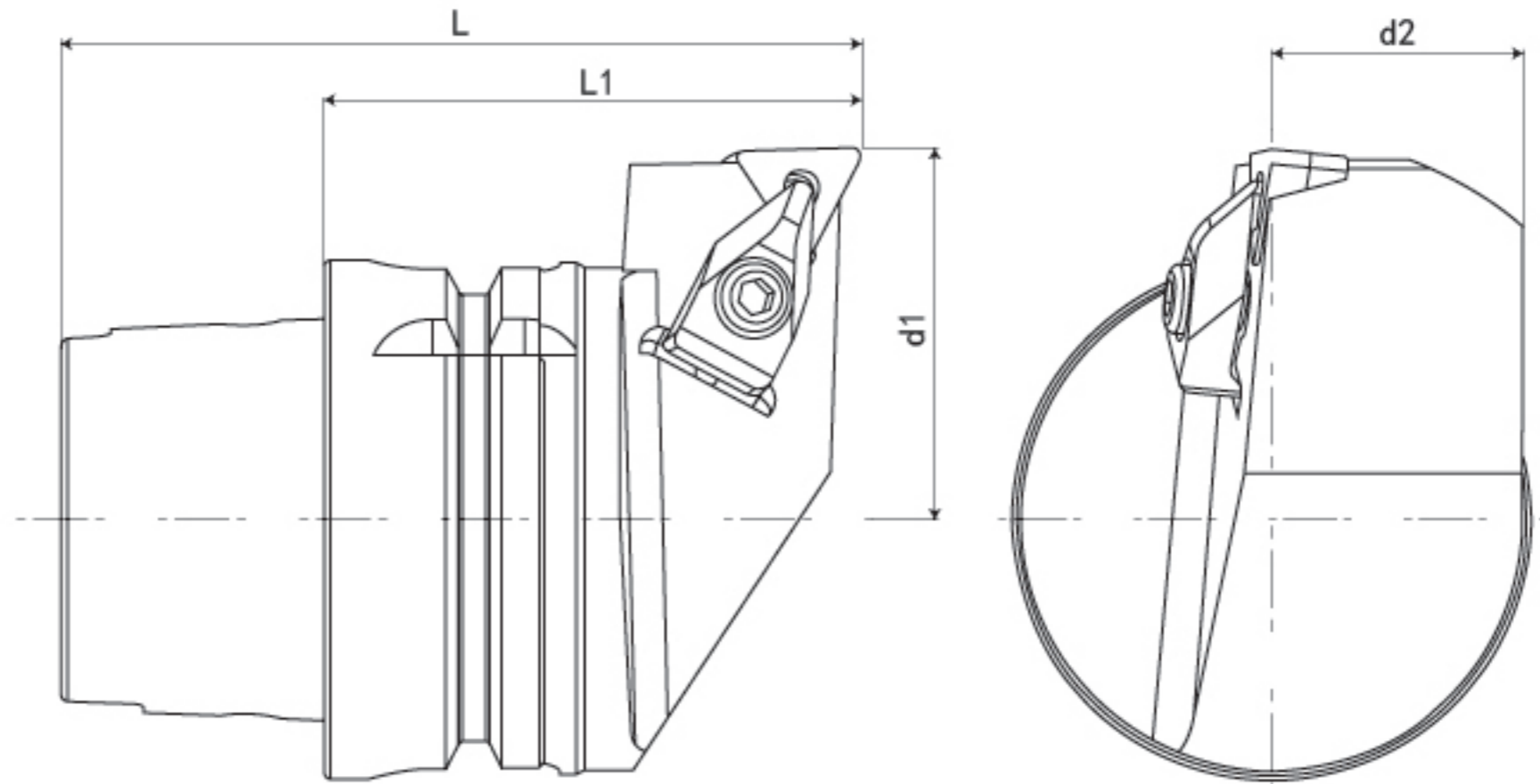

規格 Spec.	L	L1	d1	d2	刀片 Insert	重量 (KGS) Weight
HSK-T63-DTJNR-45065-16	97	65	45	31	TN..1604	1.27
HSK-T63-DTJNL-45065-16	97	65	45	31	TN..1604	1.27

### 配件表 Accessories

刀片 Insert	墊片 Shim	墊片螺絲 Shim Screw	扳手 Wrench	扭力值 (N.m) Torque	壓板 Clamp	壓板螺絲 Clamp Screw	壓板扳手 Clamp Wrench	扭力值 (N.m) Torque
TN..1604	TMS322	MLP34L-A	PL2	3.0	MC620	MS630	PL3	5.0

HSK-Turning and Milling Tool Holder  
HSK-T車銑復合力座

## DWLN 外徑車刀

## MWLN EXTERNAL TURNING TOOL

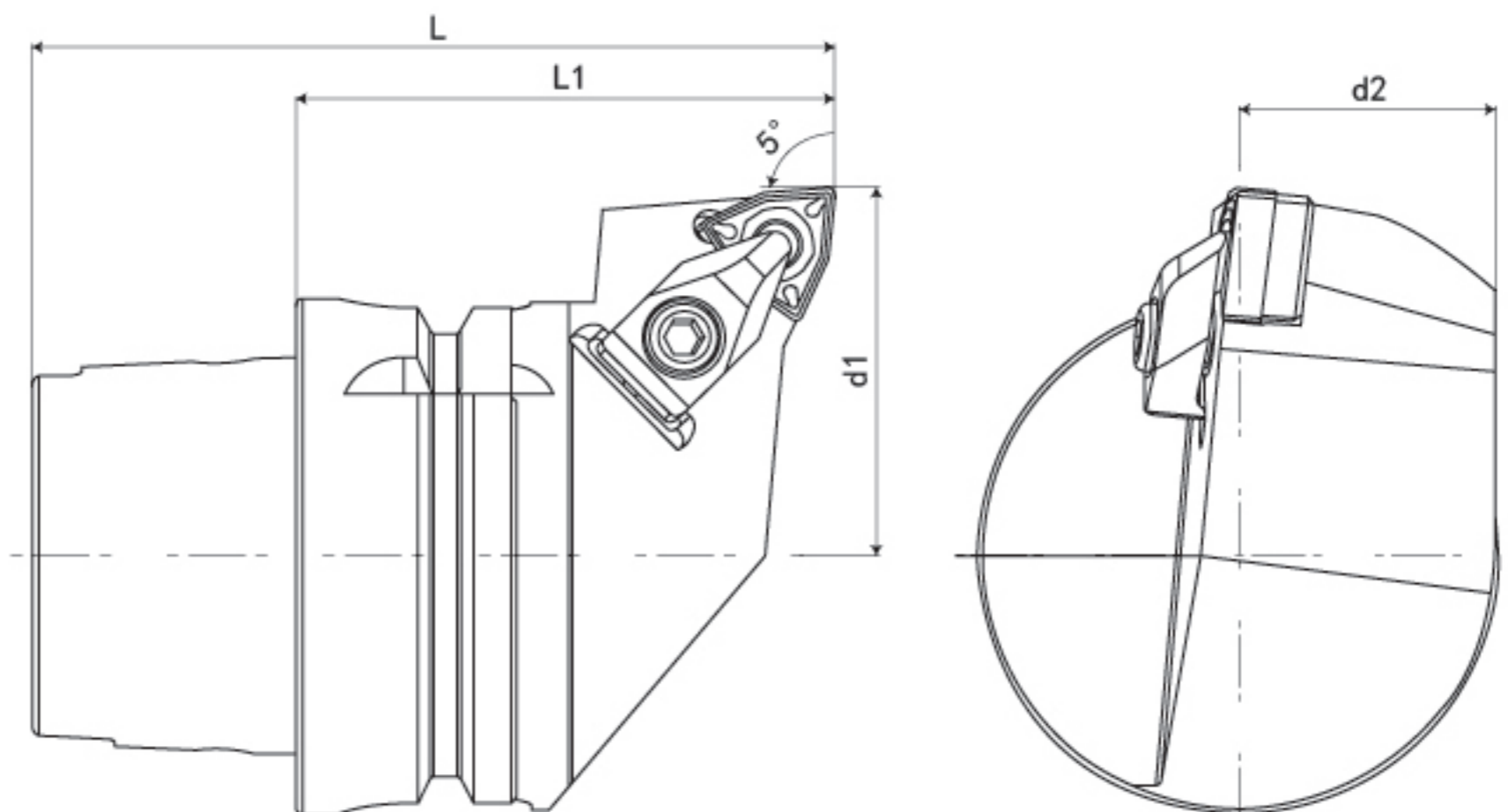

規格 Spec.	L	L1	d1	d2	刀片 Insert	重量 (KGS) Weight
HSK-T63-DWLNR-45065-08	97	65	45	31	WN..0804	1.22
HSK-T63-DWLNL-45065-08	97	65	45	31	WN..0804	1.22

### 配件表 Accessories

刀片 Insert	墊片 Shim	墊片螺絲 Shim Screw	扳手 Wrench	扭力值 (N.m) Torque	壓板 Clamp	壓板螺絲 Clamp Screw	壓板扳手 Clamp Wrench	扭力值 (N.m) Torque
WN..0804	WMS432	MLP46L-A	PL2.5	5.0	MC620	MS630	PL3	5.0

## DVLN 外徑車刀

## MVLN EXTERNAL TURNING TOOL

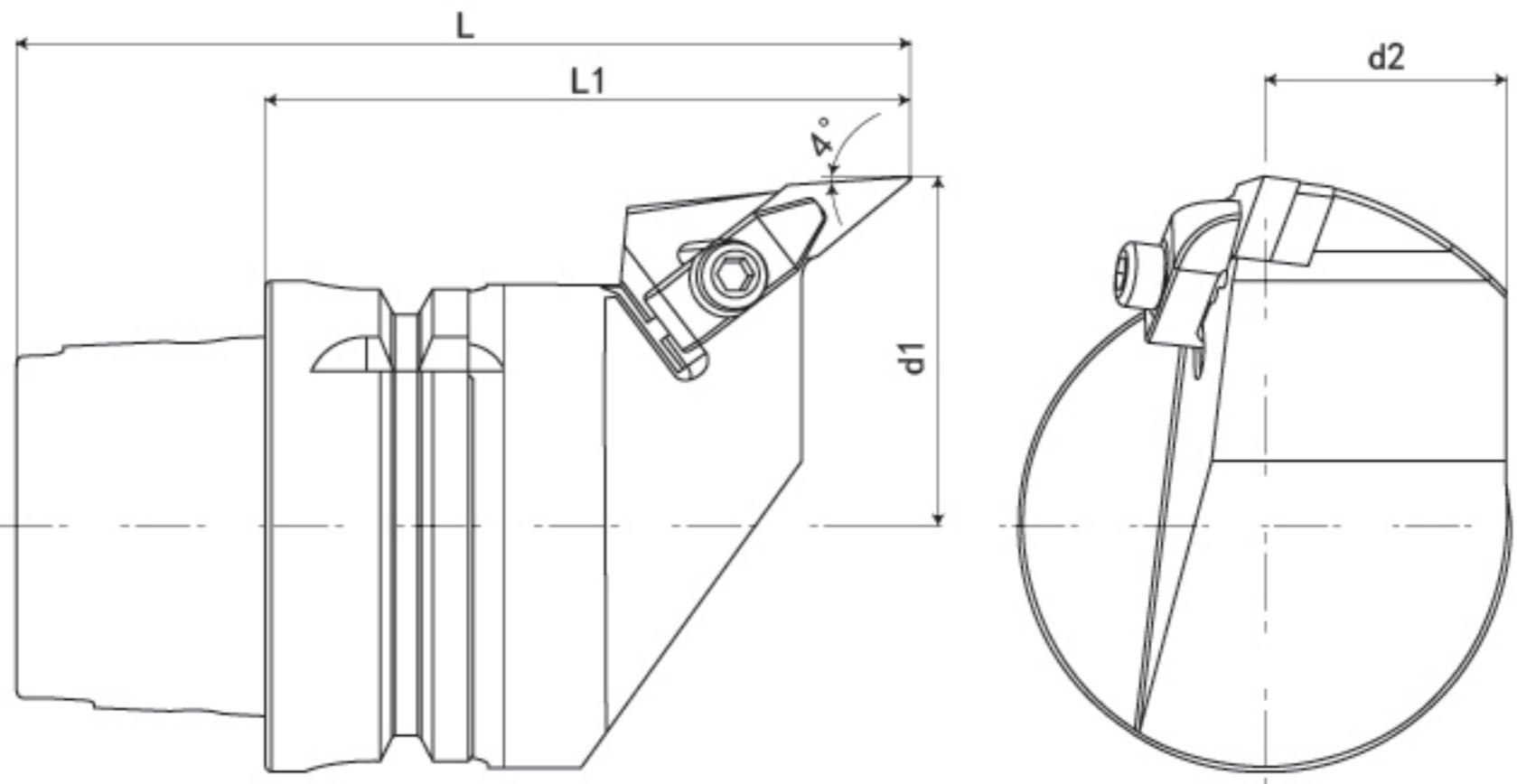

規格 Spec.	L	L1	d1	d2	刀片 Insert	重量 (KGS) Weight
HSK-T63-DVLNR-45075-16	107	75	45	31	VN..1604	1.30
HSK-T63-DVLNL-45075-16	107	75	45	31	VN..1604	1.30

### 配件表 Accessories

刀片 Insert	墊片 Shim	墊片螺絲 Shim Screw	扳手 Wrench	扭力值 (N.m) Torque	壓板 Clamp	壓板螺絲 Clamp Screw	壓板扳手 Clamp Wrench	扭力值 (N.m) Torque
VN..1604	VMS322	MLP34L-A	PL2	3.0	MC622	MS630	PL3	5.0

## DCMN 外徑車刀

## DCMN EXTERNAL TURNING TOOL

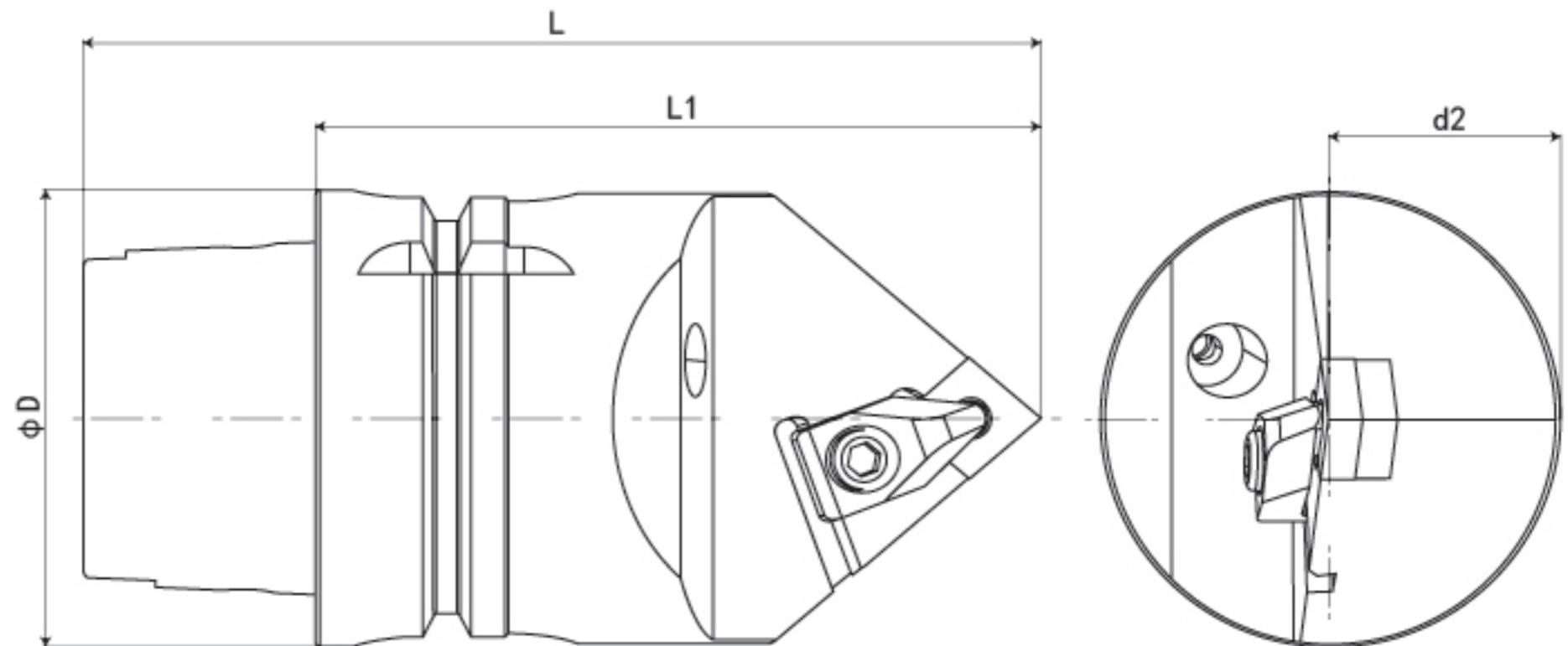

規格 Spec.	L	L1	刀片 Insert	重量 (KGS) Weight
HSK-T63-DCMNN-00100-12	132	100	CN..1204	1.68
HSK-T63-DCMNN-00140-12	172	140	CN..1204	1.68

### 配件表 Accessories

刀片 Insert	墊片 Shim	墊片螺絲 Shim Screw	扳手 Wrench	扭力值 (N.m) Torque	壓板 Clamp	壓板螺絲 Clamp Screw	壓板扳手 Clamp Wrench	扭力值 (N.m) Torque
CN..1204	CMS432	MLP46L-A	PL2.5	5.0	MC620	MS620	PL3	5.0

## DDNN 外徑車刀

## DDNN EXTERNAL TURNING TOOL

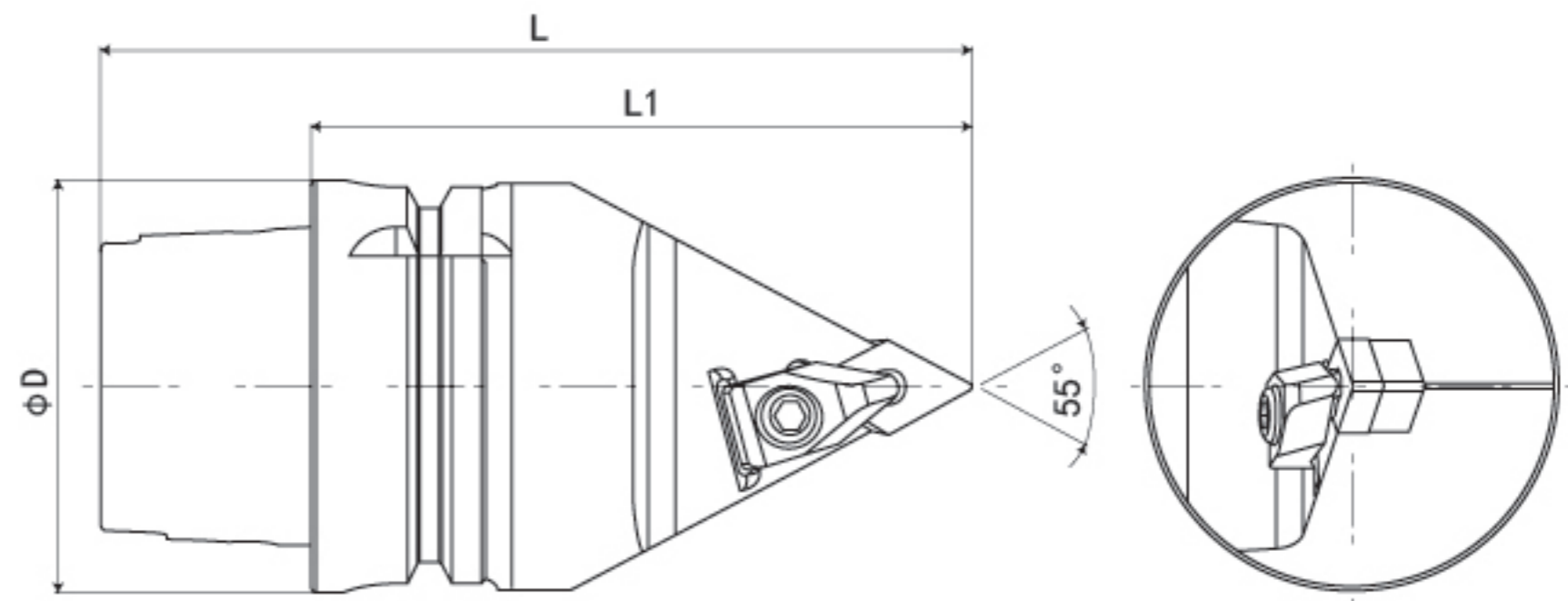

規格 Spec.	L	L1	D	刀片 Insert	重量 (KGS) Weight
HSK-T63-DDNNN-00100-15	132	100	63	DN..1504	1.55
HSK-T63-DDNNN-00140-15	172	140	63	DN..1504	1.55

### 配件表 Accessories

刀片 Insert	墊片 Shim	墊片螺絲 Shim Screw	扳手 Wrench	扭力值 (N.m) Torque	壓板 Clamp	壓板螺絲 Clamp Screw	壓板扳手 Clamp Wrench	扭力值 (N.m) Torque
DN..1504	DMS442	MLP46L-A	PL2.5	5.0	MC622	MS625	PL3	5.0

HSK-T Turning and Milling Tool Holder  
HSK-T 車銑復合力座

## DTEN 外徑車刀

## DTEN EXTERNAL TURNING TOOL

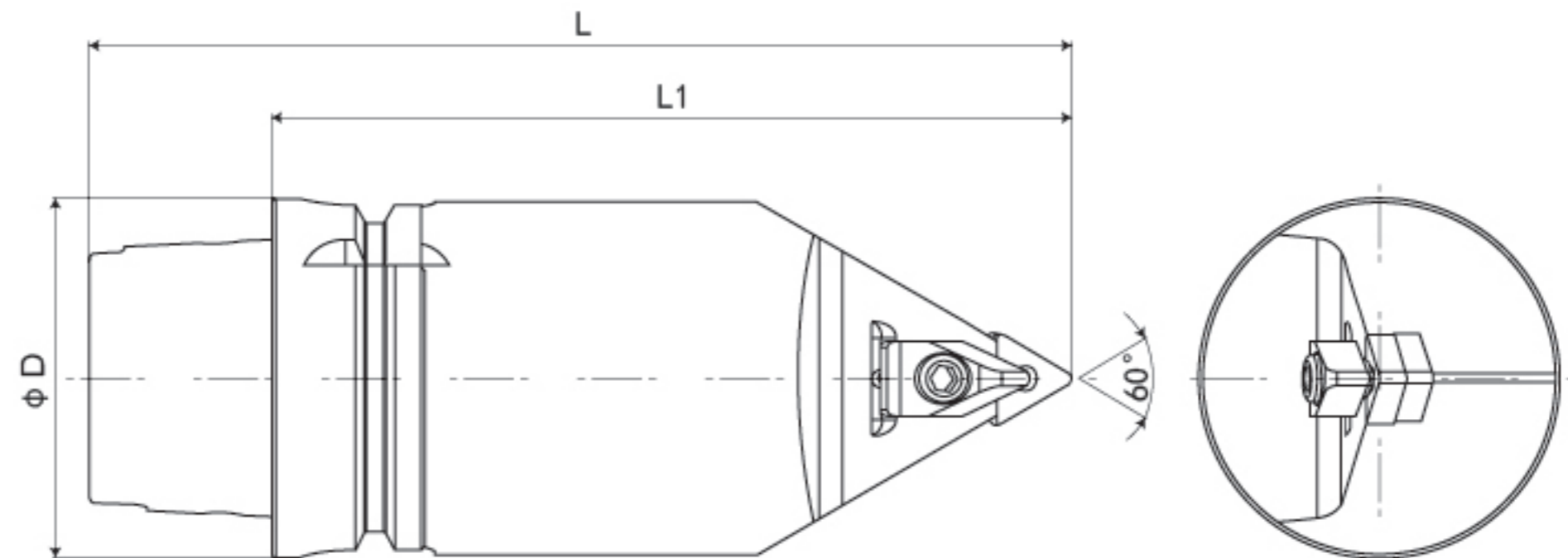

規格 Spec.	L	L1	D	刀片 Insert	重量 (KGS) Weight
HSK-T63-DTENN-00100-16	132	100	63	TN..1604	1.62
HSK-T63-DTENN-00140-16	172	140	63	TN..1604	1.62

### 配件表 Accessories

刀片 Insert	墊片 Shim	墊片螺絲 Shim Screw	扳手 Wrench	扭力值 (N.m) Torque	壓板 Clamp	壓板螺絲 Clamp Screw	壓板扳手 Clamp Wrench	扭力值 (N.m) Torque
TN..1604	TMS322	MLP34L-A	PL2	3.0	MC620	MS630	PL3	5.0

## DWMN 外徑車刀

## DWMN EXTERNAL TURNING TOOL

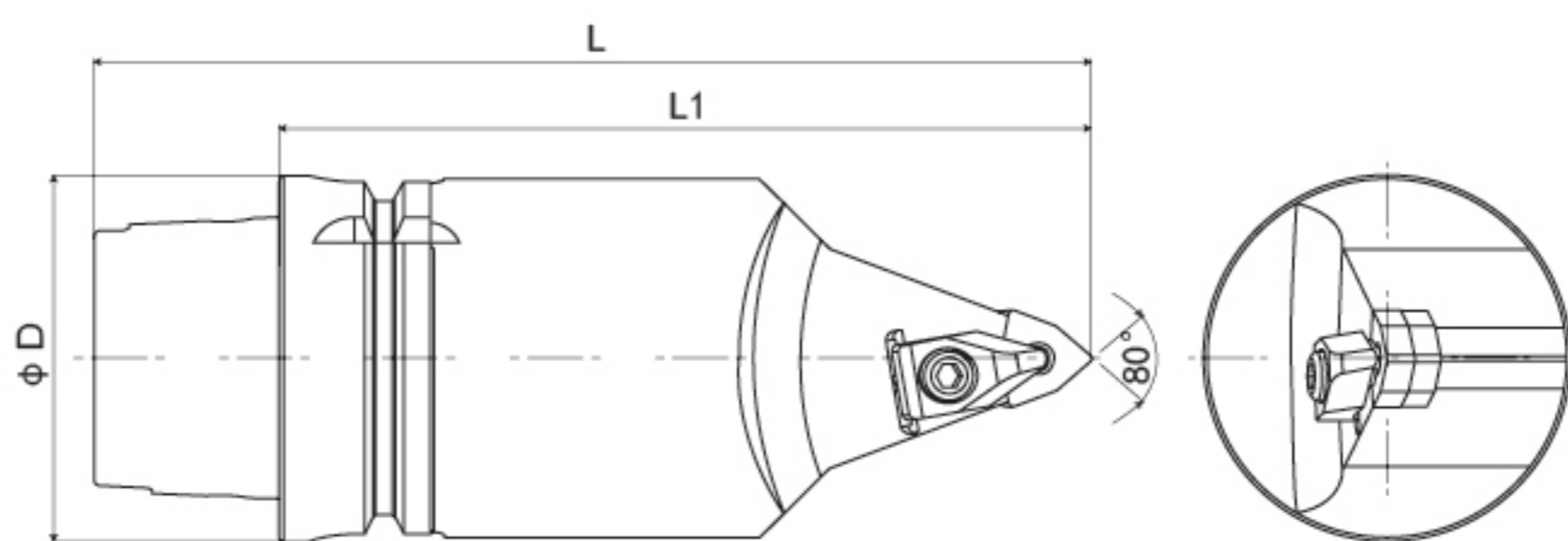

規格 Spec.	L	L1	D	刀片 Insert	重量 (KGS) Weight
HSK-T63-DWMN-00100-08	132	100	63	WN..0804	1.48
HSK-T63-DWMN-00140-08	172	140	63	WN..0804	1.48

### 配件表 Accessories

刀片 Insert	墊片 Shim	墊片螺絲 Shim Screw	扳手 Wrench	扭力值 (N.m) Torque	壓板 Clamp	壓板螺絲 Clamp Screw	壓板扳手 Clamp Wrench	扭力值 (N.m) Torque
WN..0804	WMS432	MLP46L-A	PL2.5	5.0	MC620	MS630	PL3	5.0

## DVVN 外徑車刀

## DVVN EXTERNAL TURNING TOOL

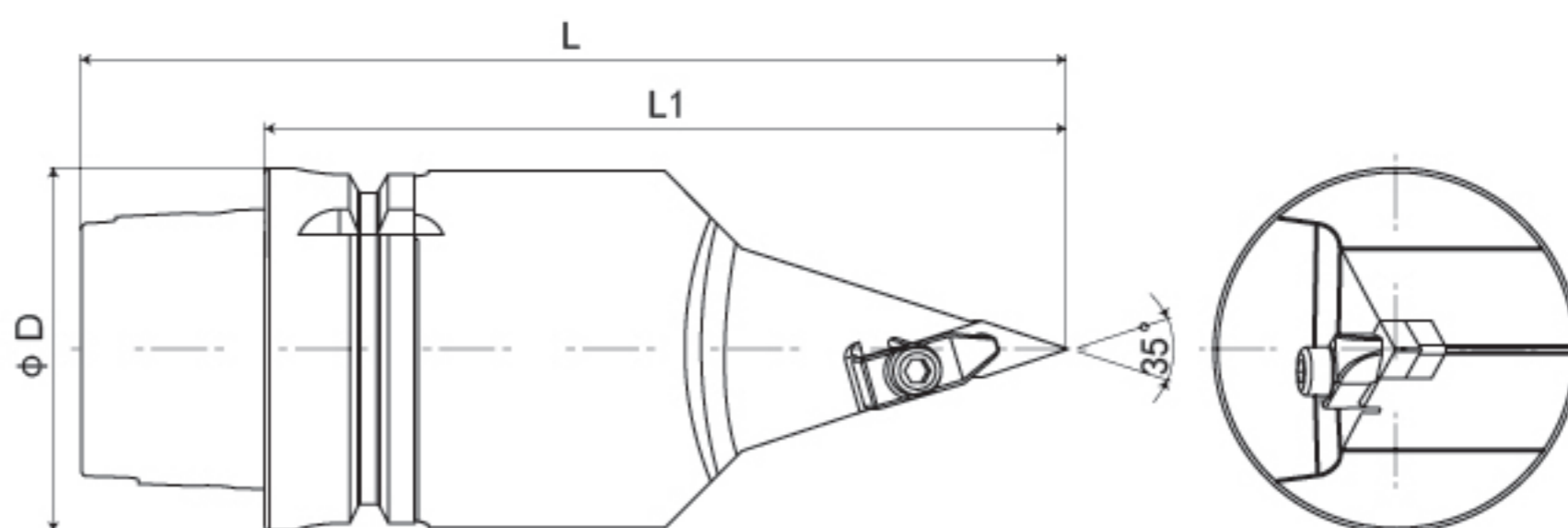

規格 Spec.	L	L1	D	刀片 Insert	重量 (KGS) Weight
HSK-T63-DVVNN-00100-16	132	100	63	VN..1604	1.40
HSK-T63-DVVNN-00140-16	172	140	63	VN..1604	1.40

### 配件表 Accessories

刀片 Insert	墊片 Shim	墊片螺絲 Shim Screw	扳手 Wrench	扭力值 (N.m) Torque	壓板 Clamp	壓板螺絲 Clamp Screw	壓板扳手 Clamp Wrench	扭力值 (N.m) Torque
VN..1604	VMS322	MLP34L-A	PL2	3.0	MC622	MS630	PL3	5.0